



Operation, Installation and
Instruction Manual
for
Reach-In and Roll-In
Refrigerators, Freezers and Warmers

BMIL International, Inc.

A Division of BALMAC International, Inc.

61 Broadway, Suite 1900 • New York, NY 10006-2701
212-898-9699 • Fax: 212-514-9234 - bmil@bmil.com

Operators Manual

Table of Contents	Page
RECEIVING YOUR NEW MODEL.....	1
GENERAL INFORMATION AND IMPORTANT OPERATING FACTS	1
UNCRATING YOUR NEW MODEL	2
INSTALLATION AND LOCATION.....	2
CLEARANCES	2
VENTILATION.....	2
FLOOR LOADS.....	3
INSTALLING LEGS AND LEVELING REACH-IN MODELS	4
MOUNTING ROLL-IN MODELS IN PLACE AND LEVELING	4
INSTALLING CASTERS AND LEVELING REACH-IN MODELS	5
INSTALLING CONDENSATE EVAPORATOR.....	6
REMOVAL OF DOORS AND DOOR ADJUSTMENT	7
REMOVAL OF GRILL	8
INITIAL CLEANING PROCEDURE.....	8
START-UP PROCEDURE	9
ELECTRICAL CONNECTIONS.....	9
115 VOLT, 60 HZ, 1 PHASE CONNECTION	9
208-230 VOLT, 60 HZ, 1 PHASE CONNECTION.....	9
SPECIAL VOLTAGE CONNECTIONS.....	9
START-UP CHECKLIST	10
REMOTE APPLICATIONS	10
OPERATION.....	11
THERMOMETER CALIBRATION	11
CALIBRATION CHECK.....	11
DIAL THERMOMETER	11
DIGITAL THERMOMETER	11
REFRIGERATOR SYSTEM AND ADJUSTMENT.....	13
FREEZER SYSTEM AND ADJUSTMENT	14
DEFROST OPERATION	14
WARMER SYSTEM AND ADJUSTMENT.....	15
EVAPORATOR ASSEMBLY	16
<i>LOW-PROFILE, CEILING-MOUNT EVAPORATOR ASSEMBLY</i>	<i>16</i>
<i>PLUG-TYPE, TOP-MOUNT EVAPORATOR ASSEMBLY.....</i>	<i>17</i>
INTERIOR REACH-IN ACCESSORIES	18
<i>SHELVING INSTALLATION</i>	<i>18</i>
<i>OPTIONAL INTERIOR ACCESSORIES.....</i>	<i>19</i>
SAFETY PRECAUTIONS	20
MAINTENANCE.....	20
PERIODIC CLEANING PROCEDURE.....	20
SLIDING AND HINGED GLASS.....	21
GENERAL PREVENTATIVE MAINTENANCE	21
PARTS AND SERVICE	22
TROUBLESHOOTING AND SERVICING GUIDE	23
WIRING DIAGRAMS	26

RECEIVING YOUR NEW MODEL

Congratulations on your recent purchase of Bally refrigerator superior food equipment products! When your shipment arrives, please thoroughly examine the shipping crate for any punctures, dents, or signs of rough handling. It is in your best interest to partially remove or open the shipping container in order to examine the model for any concealed damages which may have occurred during shipment. If the model is damaged, it must be noted on the delivering carrier's delivery slip or bill of lading (see "filing a damage claim" under warranty section).

GENERAL INFORMATION AND IMPORTANT OPERATING FACTS

This manual has been compiled to aid in the installation, operation and maintenance of your new equipment. Please take the time to read all of the material in order to become more familiar with your equipment and its operation, and enjoy optimum performance.

Important Note: All value and designer line freezers have an energy-saving fan delay control to prevent the interior fans from operating until the evaporator coil becomes chilled. Therefore, on initial start-up, the fans will not turn on immediately. **This is a normal mode of operation.** Allow sufficient time for the evaporator coil to reach its operating temperature (approximately 20 minutes).

No floor drains or plumbing connections are required since all models are completely self-defrosting and use an automatic defrost condensate water evaporating system (see "condensate evaporator installation" under installation and location section).

All cabinets must be given sufficient time to reach normal operating temperature before placing any food inside. For refrigerators, approximately 2 hours of operation are required to lower the cabinet temperature to 40 degrees f. Freezers require approximately 4 hours of operation to lower the cabinet temperature to 0 degrees f (see "operation" section for further information).

Never overload top shelf with product so as to block or restrict cabinet airflow. Doing so will result in poor performance, decrease in efficiency and possible need for service to de-ice evaporator.

Prior to factory shipping, all models are performance run tested for a minimum of 12 hours providing a highly sophisticated temperature analysis recording exclusive to each individual cabinet. This recording is supplied within this manual packet. A final leak check, vibration, noise level and visual examination is made by a qualified quality control team to assure a quality product. The carrier signs to this effect when he accepts the product for shipping. To insure the maximum in safety and sanitation, all models are listed under the reexamination service of underwriter's laboratories and with the national sanitation foundation.

UNCRATING YOUR NEW MODEL

The shipping container should remain on your model as protection against dents or scratches while transporting it to the actual set-up location. Remove the shipping container only at the last possible moment by following these simple steps:

1. Using a pry bar, pry off and remove crate end bottom staples.
2. Pry off and remove crate front and rear bottom staples.
3. Slide crate upward and remove it, being careful not to rub against cabinet.

There are up to four (4) bolts securing the cabinet to the wooden skid. The bolts are located at each end on the underside of the skid. In order to remove these bolts it is advisable to tilt the cabinet backwards and place wooden blocks at each end in order to hold it in its tilted position. Using a 3/4" socket or open end wrench, remove the bolts and carefully slide the model off of the skid. After skid removal, the cabinet should never be moved without dollies or rollers to avoid damage to the cabinet bottom or floor.

Important Note: Do not under any circumstances lay your new model on its front or sides. Only for a brief period, may you lay the model on its back and only then, when its properly blocked so as not to crush the condensate drain tubing and also to allow provision for your hands in order to set it in its upright position without inflicting damage to the cabinet. **Do not plug in and operate model for at least three (3) hours after cabinet is set upright from being on its back as damage could result to the compressor.**

INSTALLATION AND LOCATION CLEARANCES

Before moving the cabinet to its final point of installation, accurately measure all doorways or passages to assure clearance. If additional clearance is needed, cabinet doors and grill can be easily removed (see instructions outlined in "removal of doors" and "removal of grill" sections).

VENTILATION

The final location site of your air cooled refrigerator or freezer must be able to provide a large quantity of cool, clean air. The refrigeration system operates most efficiently and trouble-free with cool, dry air circulation. Avoid locations near heat and moisture generating equipment such as stoves, ovens, cooking ranges, fryers, dish washers, steam kettles, etc., and also direct sunlight where temperatures can be in excess of 100 degrees f. Also, do not select a location in an unheated room or area where temperatures may drop below 55 degrees f. Air supply to the condensing unit is equally important. Restricting the air supply will place an excessive heat load on the condensing unit and adversely effect its operating efficiency.

Important Note: To assure sufficient air supply and circulation to the condensing unit, a **minimum clearance of 12" above the grill and 3" on each side and back of the cabinet must be provided** (see figure 1). If necessary, special venting or air supply ducts must be installed by the installer for this purpose. Do not at any time obstruct the grill area in front of the cabinet in any way, and never place or store anything on top of the cabinet machine compartment. These rules are essential for maximum cooling capacity and long life of refrigeration parts.

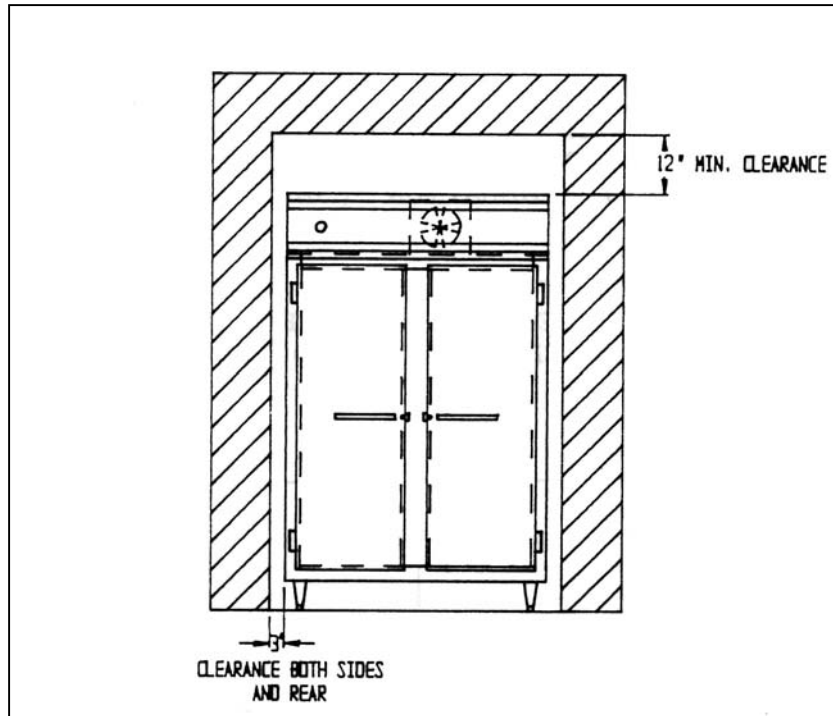

FIGURE 1
MINIMUM CLEARANCE DIMENSIONS

FLOOR LOADS

The floor at the final location site must be level, free of vibration and strong enough to support the total combined weights of your new model plus the maximum product load which might be placed into it. A fully loaded reach-in or roll-in model may reach 2,000 - 3,000 pounds. To estimate the possible product load weight, assume that each cubic foot of storage space weighs approximately 35 pounds. Multiply 35 pounds by the amount of cubic feet in the cabinet and obtain the product load weight. For example, a 20 cubic foot refrigerator can hold approximately 700 pounds of product (35×20) and assuming the refrigerator itself weighs 300 pounds, the total combined weight of cabinet and product is approximately 1000 pounds. Therefore, the floor in this example must be capable of supporting up to 1000 pounds.

INSTALLING LEGS AND LEVELING REACH-IN MODELS

Your new reach-in model is supplied with adjustable type legs for leveling purposes. Each single and two section model has four leg mounting holes on its case bottom, and three section models have six leg mounting holes. Legs are packed in the accessory carton from which they must be removed and installed on the cabinet case bottom (see figure 2). In order to install the legs, carefully tip the cabinet rearward adding four (4) 2" wood blocks underneath and simply screw the threaded leg studs into the case bottom front leg holes. Repeat this procedure by tilting the cabinet in the opposite direction and install the remaining legs. Make sure the legs are tightened extremely well or the entire model will sway or rock with each opening or closing of the doors, possibly causing damage to the case bottom. This procedure should be performed close to the final installation site and allow access to the rear of the cabinet for condensate evaporator installation (see "condensate evaporator installation" under installation and location section).

To assure your cabinet is level, all legs are equipped with bullet-type leveling bolts. These bolts can be turned by hand or by wrench, clockwise or counterclockwise to level the cabinet.

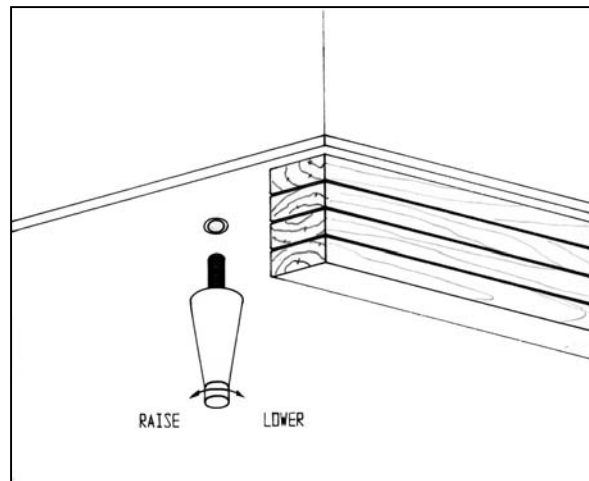

FIGURE 2
LEG INSTALLATION

MOUNTING ROLL-IN MODELS IN PLACE AND LEVELING

Your new roll-in model is designed and constructed to be mounted directly on the floor without legs or casters. The floor **must** be level and the base of the cabinet should be sealed to the floor around its entire perimeter. If the floor is not level, it must be made level prior to mounting your roll-in model.

Your roll-in model comes with one cart ramp per door opening. To install the ramp(s), simply open the cabinet door and position the ramp slots onto the screws located along the cabinet bottom front. If the door wiper rubs along the ramp to the extreme where the door will not self-close, you will need to adjust the door (see "door adjustment" section) or level the cabinet as explained above.

Important Note: It is extremely important that your new reach-in or roll-in model is perfectly level for proper operation. If it is not level, the following adverse conditions will become apparent:

1. The door(s) will not be properly aligned and consequently will not provide a good seal. Roll-in door wiper(s) may bind.
2. Your model will run excessively due to improper door seal(s).
3. An excessive amount of ice will accumulate inside the cabinet, around the door opening(s) and especially on the finned evaporator coil. If allowed to continue, ice will eventually block the coil and the model will fail. This will result in the loss of all food stored within the cabinet.
4. Defrost water will fail to drain properly and will overflow the evaporator coil drain pan and into the cabinet of both refrigerator and freezer models.

INSTALLING CASTERS AND LEVELING REACH-IN MODELS

If you wish to install casters on your new reach-in model, follow the steps above for "installing legs" to install the casters, making sure again that the casters are tightened extremely well (see figure 3). If the casters are not installed tightly, the cabinet will sway or rock with each opening or closing of the doors, possibly causing damage to the case bottom.

To assure that your cabinet is level, caster cups must be installed under the casters which need leveling. Caster cups are not provided with your new model but can be purchased at most hardware or furniture stores. **Do not attempt to level casters by unscrewing them from the case bottom as this will cause damage to the cabinet bottom and leg hole threads, voiding all warranties.**

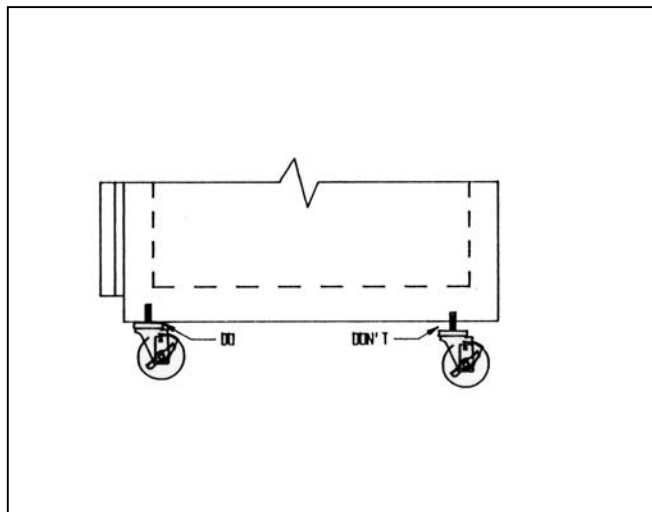

FIGURE 3
CASTERS MUST BE TIGHT TO CABINET BOTTOM

INSTALLING CONDENSATE EVAPORATOR

No floor drains or plumbing connections are required since all models use an automatic condensate water evaporating system. All *designer line* models utilize a unique hot gas condensate water evaporating system which is completely self-contained and no further assembly or maintenance is required (these models are recognized by their evaporator coil which is located out of the food zone in an insulated plug-box housing next to the condensing unit). All *value line* models are supplied with an electric condensate evaporator pan and mounting bracket packed in the accessory carton. To install the condensate pan on *value line* models only, remove both mounting screws located on the bottom of the cabinet back and install the mounting bracket on the case bottom as shown in figure 4. Slide the condensate pan onto the bracket, install the drain tube into the pan making sure it is not blocked or kinked, and plug the ten foot power cord into the receptacle labeled "vaporizer" located on the case top electrical box.

IMPORTANT NOTE: It is extremely important to be sure that the condensate pan is plugged into its correct receptacle labeled "vaporizer" and that the condensing unit is plugged into its correct receptacle labeled "condensing unit".

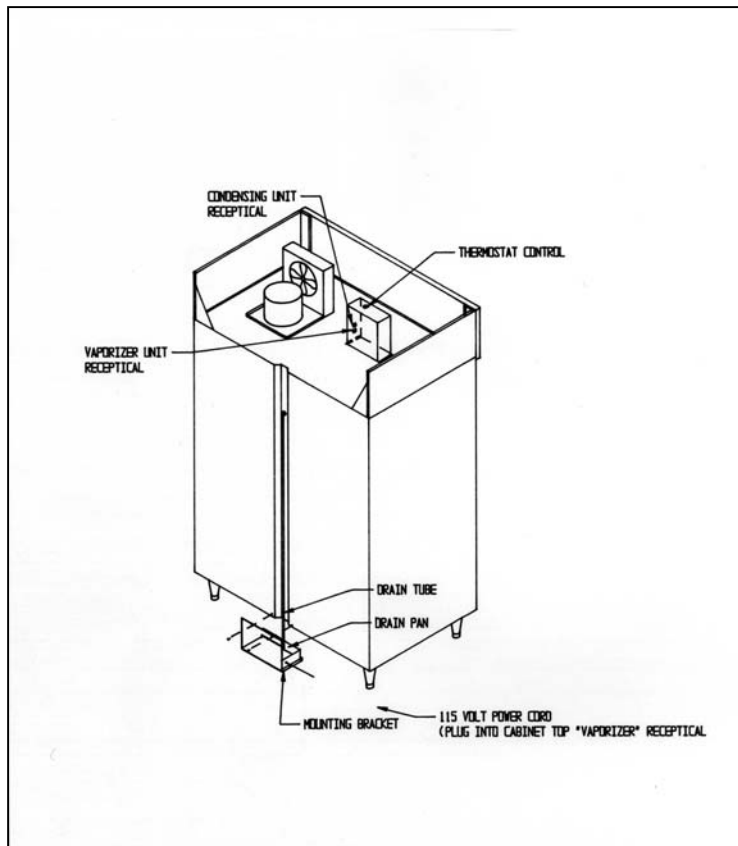

FIGURE 4
CONDENSATE EVAPORATOR INSTALLATION

REMOVAL OF DOORS AND DOOR ADJUSTMENT

During installation, it may become necessary to remove the cabinet doors to facilitate passage through narrow doorways or hallways. To remove a door, pry off all hinge covers using a sharp tool or knife (see figure 5). Swing the door to the open-door position (90 degrees) and carefully lift the door upward, removing the door from the hinge bodies. If it is necessary to remove the hinge bodies from the cabinet face, be extremely careful not to lose the light switch pin located inside all top hinge bodies. To reinstall the door, reverse the above procedure.

All doors have been aligned at the factory, however vibration during transportation may cause doors to shift and realignment may be necessary. **If the door(s) require realignment, proceed as follows:**

1. Pry off all hinge covers using a sharp tool or knife.
2. For each door, loosen the screws which secure the hinge bodies to the cabinet face and slide the door into alignment. Hold the door firmly in place and tighten all screws securely.

If the door gasket(s) do not seal properly to the cabinet face and there are gaps between the gasket and the face on the hinge edge, proceed as follows:

1. For each door, loosen all screws which are directed into the edge of the door and push the door towards the cabinet eliminating the gap. Hold the door firmly in place and tighten all screws securely.
2. Replace all snap-on hinge covers.

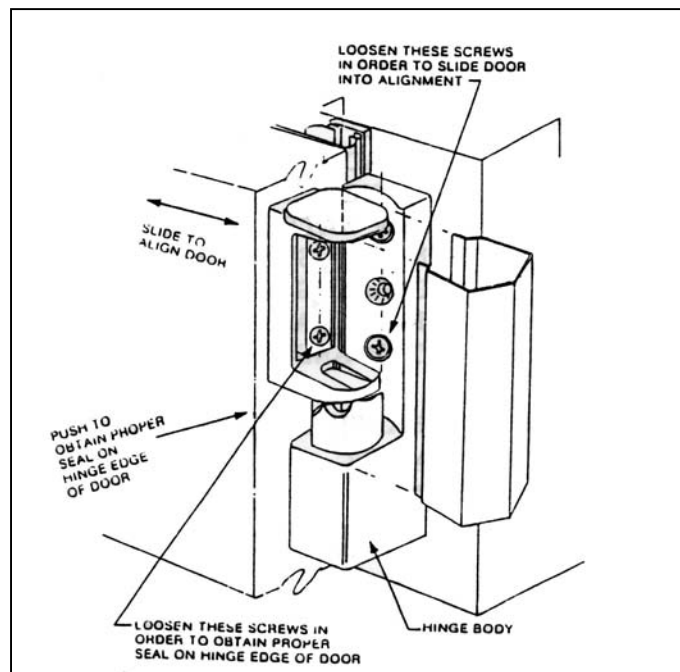

FIGURE 5
DOOR ADJUSTMENT AND REMOVAL

REMOVAL OF GRILL

To remove the grill, loosen all four (4) grill mounting screws located on the backside of the grill one or two turns. Simply lift grill up off of its mounting screws and out. To replace the grill, line up the grill mounting screws with the keyhole slots located on the cabinet body, push in on the grill and down.

Important note: If the model is provided with a digital or dial thermometer, the front grill cannot be completely removed from the cabinet without first removing the thermometer bulb from inside the cabinet. However, enough capillary tubing and/or wiring cable has been provided to allow the grill to be laid across the top of the cabinet after it has been removed. Take care not to damage the capillary tubing when handling the grill.

If it is necessary to remove the thermometer bulb from inside of the cabinet, first locate the thermometer bulb cover and remove the thumbscrews securing it in place. On *value line* models, the thermometer bulb cover is located on the interior top left corner towards the front of the cabinet. On *designer line* models, the thermometer bulb is located on the interior top under the air duct. Once the cover is removed, carefully grasp the bulb and push it back through the cabinet hole. The thermometer bulb and grill can now be removed from the cabinet. When reinstalling the thermometer bulb, be sure to replace the permagum sealant around the hole after inserting the bulb.

INITIAL CLEANING PROCEDURE

Prior to start-up and before placing any food inside of your new reach-in or roll-in model, the interior of the cabinet should be thoroughly cleaned. Washing with a mild soap and warm water solution is recommended for cleaning the aluminum and stainless steel surfaces of your cabinet. This should be followed by cleaning with a baking soda solution (three (3) tablespoons of baking soda to each quart of warm water). Rinse thoroughly with clear water and dry with a clean, soft cloth.

Important Note: Never use harsh detergents, cleaners, scouring powders or chemicals when cleaning your model. Failure to dry the interior surfaces after cleaning may result in a streaking or staining of the metal.

Complete cleaning procedures and precautions are listed in the "periodic cleaning procedure" under the maintenance section.

START-UP PROCEDURE **ELECTRICAL CONNECTIONS**

To insure proper operation, your new model must be connected to an individual circuit that can supply the full voltage as stated on the cabinet serial data plate. For correct voltage, power draw, and wire accommodations, check the data on the serial data plate located on the inner right wall of your new model. Verify that this information exactly matches the electrical characteristics at the installation location. An electrical wiring diagram, located on the upper cabinet end panel next to the electrical console box, should also be consulted during connection.

Important Note: The condensing unit supplied with all self-contained models is designed to operate with a voltage fluctuation of $\pm 10\%$ of the voltage indicated on the cabinet serial data plate. Full voltage of the correct service, on an individual line not affected by the operation of other electrical appliances, must be available to the condensing unit at all times. **Burnout of the compressor due to exceeding the high or low voltage limits is easily detected and will automatically void the factory warranty.**

115 VOLT, 60 HZ, 1 PHASE CONNECTION

All 115 volt models are provided with a U.L. approved power cord and polarized plug which is factory installed.

Warning: Any alterations to this cord and plug could cause an electrical hazard and will void the factory warranty.

To insure proper operation, this equipment must be plugged into a NEMA 5-15R compatible, grounded receptacle that can supply the full voltage as stated on the serial data plate.

208-230 VOLT, 60 HZ, 1 PHASE CONNECTION

All 208-230 volt models are to be permanently connected and are provided with four (4) field wiring leads which exit the electrical console box located in the machine compartment behind the front grill. The cabinet circuitry is 115 volts and the condensing unit is 208-230 volts in which the wiring includes a neutral and a mechanical ground. This wiring should be connected to the appropriate power source by a qualified electrician and must conform to all local electrical codes.

SPECIAL VOLTAGE CONNECTIONS

When models are ordered from the factory with special, optional voltages, connections should be made as required on the electrical wiring diagram provided on the upper cabinet end panel next to the electrical console box.

START-UP CHECKLIST

After your model has been installed, leveled, cleaned, and electrically connected in accordance with this manual, please take the time before start-up to observe the following precautions to assure troublefree operation:

1. Check that all exposed refrigeration lines are free of severe dents or kinks.
2. Check the condenser fan and evaporator fans for freedom to rotate without any obstructions
3. Make sure that the cabinet is properly leveled (see "leveling" under installation and location section).

The system should run smoothly and quietly in accordance with generally accepted commercial standards. If any unusual noises are heard, turn the unit off immediately and check for any obstructions of the condenser or evaporator fans. Fan motors, fan blades, or fan housings can be jarred out of position through rough handling in transit or during installation.

Important Note: All freezer models have an energy-saving fan delay control to prevent the interior fans from operating until the evaporator becomes chilled. Therefore, on initial start-up, the fans will not turn immediately. **This is a normal mode of operation.** Allow sufficient time for the evaporator coil to reach its operating temperature (approximately 20 minutes).

Caution: If unit is unplugged or disconnected for any reason, allow several minutes (5-6 minutes) before turning the unit back on to allow the system pressures to equalize. Disregarding this procedure could cause an overload and prevent the unit from operating.

REMOTE APPLICATIONS

All models are available for purchase as remote models in which case the condensing unit is purchased separately and installed at the time of installation. All remote models are equipped with an expansion valve located within the evaporator coil housing, and both liquid and suction lines stubbed and extending out from the cabinet case top behind the front grill. Installation of the refrigeration accessories, condensing unit, and electrical hook-up should be performed by qualified refrigeration personnel of a competent refrigeration company only.

OPERATION

All cabinets must be given sufficient time to reach normal operating temperature before placing any food inside. Refrigerators are designed to maintain an ideal cabinet temperature of 38`f to 40`f (3.3`c to 4.4`c) and approximately 2 hours of operation are required to reach this temperature. Standard freezers are designed to maintain an ideal cabinet temperature of -2`f to 0`f (-18.9`c to -17.8`c) and approximately 4 hours of operation are required to reach this temperature. Low temperature freezers are designed to maintain an ideal cabinet temperature of -16`f to -14`f (-26.7`c to -25.6`c) and approximately 6 hours of operation are required to reach this temperature.

THERMOMETER CALIBRATION

After your new model has been given sufficient time to pull down to the above specified temperature range, the exterior thermometer located on the upper grill **must** be checked for calibration accuracy. All thermometers are carefully calibrated at the factory prior to shipping but may be vibrated out of calibration through rough handling in transit, shipping vibration, or during installation.

CALIBRATION CHECK

To check calibration, an accurate, mercury thermometer (within the temperature range of your model) must be placed inside of the cabinet on the center shelf for at least 15 minutes without any door openings. At this time, note the temperature on the exterior cabinet thermometer, quickly open the door and compare it to the interior thermometer's temperature. Whatever the difference (if any) is the amount the exterior thermometer must be adjusted.

The adjustment procedure varies depending on which thermometer is equipped with your model (see figure 5).

DIAL THERMOMETER

For a dial thermometer, carefully pry the clear plastic lens cover from the thermometer body using a slotted screwdriver. To adjust the needle, hold the center hub stationary using a small slotted screw driver and very carefully grasp and turn the needle to the desired temperature using your fingers. Replace the lens cover and recheck the calibration.

DIGITAL THERMOMETER

For a digital thermometer, note how many degrees the digital display needs to be increased or decreased. Press twice directly on the mylar display towards the right center using your finger. After pressing the first time, the display should read "cal" indicating that you are in the calibration mode and after pressing the second time, the display should read either zero or a positive number or a negative number (this number is the point of origin for calibration). If your digital display needed to be increased, you must advance the point of origin by that many degrees by pressing directly on the mylar display towards the left top. If your digital display needed to be decreased you must decrease the point of origin by

that many degrees by pressing directly on the mylar display towards the left bottom. Once calibration is complete return to normal temperature mode by pressing once again on the mylar display towards the right center. Now, recheck the calibration.

Example: the digital display reads 45`f and the internal thermometer reads 40`f so, the digital display must be increased by 5`. Press the right center of the display twice and the number -1 is displayed (this is the point of origin and could have been any number). Now, press the top left of the display five times to make the -1 go to +4. Calibration is complete so press the right center of the display to return to normal temperature mode.

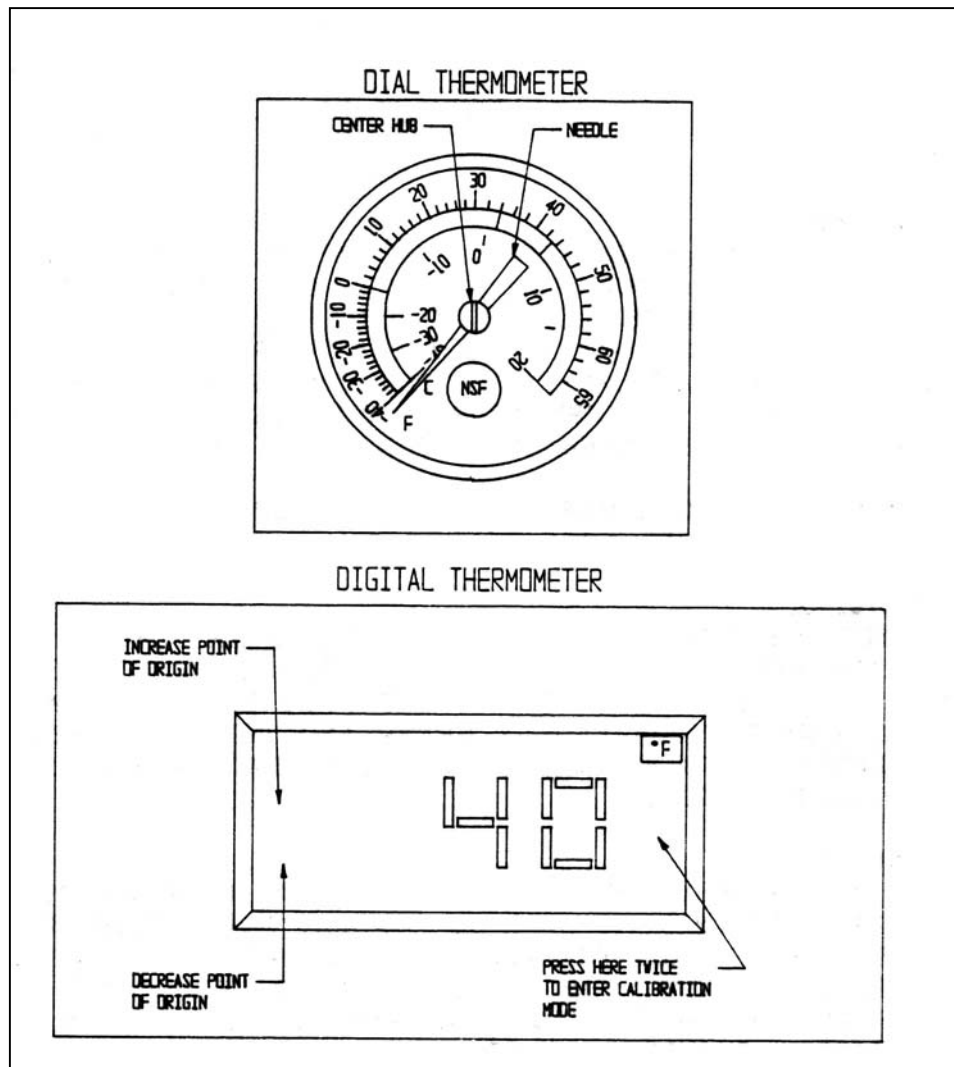

FIGURE 6
THERMOMETER CALIBRATION

REFRIGERATOR SYSTEM AND ADJUSTMENT

All self-contained *value line* and *designer line* refrigerators are designed and factory set to maintain an average cabinet temperature of 38°f. The temperature control is accessible from the top of the electrical console box located on the cabinet top behind the front grill (see figure 6). If an adjustment is necessary to maintain the above temperature range **only**, place a screwdriver into the thermostat slot and turn clockwise for a colder cabinet temperature or counterclockwise for a warmer cabinet temperature. Further adjustments out of the factory design temperature range must be made by a qualified refrigeration mechanic only.

Important Note: All refrigerators are designed with an automatic, "off-cycle" defrost system which means that defrosting occurs automatically when the compressor is not operating during an off-cycle. **Do not** set the thermostat too cold where the cabinet temperature will fall below 35°f because the evaporator will become blocked by ice since the compressor off-cycle will be considerably shortened. This will result in loss of food stored within the cabinet and require service to defrost the evaporator and re-adjust the thermostat.

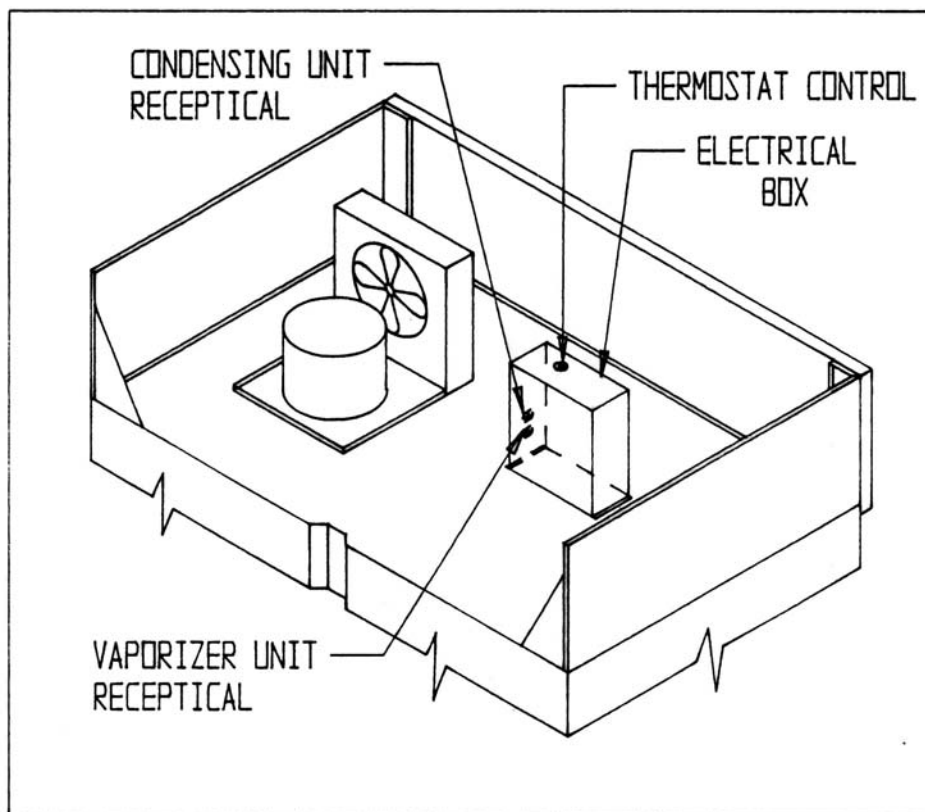

FIGURE 7
REFRIGERATOR AND FREEZER THERMOSTAT

FREEZER SYSTEM AND ADJUSTMENT

All self-contained *value line* and *designer line* standard freezers and low-temperature freezers are designed and factory set to maintain an average cabinet temperature of 0` f and -15`f respectively. All freezers are designed for the purpose of holding pre-frozen food and although they are capable of freezing small quantities of fresh food, they are not to be used as fast or blast freezers. **Do not** attempt to freeze bulk quantities of fresh foods. The temperature control is accessible from the top of the electrical console box located on the cabinet top behind the front grill (see figure 6).if an adjustment is necessary to maintain the above temperature range **only** on standard freezers, place a screwdriver into the thermostat slot and turn clockwise for a colder cabinet temperature or counterclockwise for a warmer cabinet temperature. On low-temperature freezers, place a screwdriver into the right thermostat adjustment screw (**do not turn the left differential adjustment screw**) and turn clockwise for a colder cabinet temperature or counterclockwise for a warmer cabinet temperature. Further adjustments out of the factory design temperature range must be made by a qualified refrigeration mechanic only.

DEFROST OPERATION

All freezer models are equipped with an automatic, electric defrost system consisting of an electric evaporator coil and drain pan heater, automatic electric defrost time clock, defrost high limit switch, and a fan delay switch. The defrost system is time initiated by the time clock and temperature terminated by the high limit switch. The time clock is factory preset for three (3) defrost periods per day at eight (8) hour intervals and a fail safe cut-off time of 32 minutes. These settings should be adequate for most conditions, however, depending upon use and climate conditions a fourth defrost may be required.

The defrost time clock is located in the electrical console box where a window allows access to the timer dial. To set the time of day on the defrost time clock, turn the knob on the center dial of timer face counterclockwise as the arrows indicate until the correct time of day is lined up with the "time" arrow on the upper left corner of the clock (see figure 8). It will be necessary to reset the time of day on the timer if the freezer is turned off or has loss of power. To relocate and/or add a defrost period, simply unscrew the defrost pins located around the outer dial and screw them into the desired time slots (an additional pin is located in a storage slot on the right side of the dial).

Important Note: All freezers have a unique, energy-saving defrost cycle. It is time initiated, temperature terminated, with an automatic, auxiliary time cut-off safety to minimize electrical consumption and provide for the shortest possible heating cycle. This safety time cut-off is factory set at 32 minutes and should not require any further adjustment.

After defrost, the fan delay control prevents the evaporator fans from operating until the evaporator coil has reached a temperature of 32°F (approximately 20 minutes) thus, minimizing warm air circulation inside the cabinet. Therefore, during initial start-up, and after each defrost cycle, the fans will not turn on immediately.

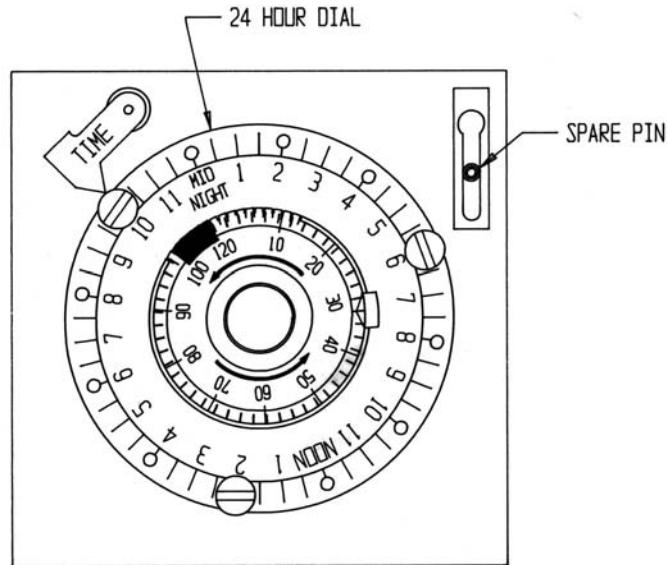

FIGURE 8
DEFROST TIMER SETTING

WARMER SYSTEM AND ADJUSTMENT

All *designer line* warming cabinets are designed with an operating range of 90°F to 180°F and factory performance run tested to maintain an average cabinet temperature of 150°F. Always preheat your new warming cabinet to the desired temperature before placing any food into it. To operate, turn the thermostat knob located on the upper grill panel, from the "off" position to the desired cabinet temperature. When the desired temperature is reached and displayed on the exterior thermometer, preheating is complete and the cabinet is ready to be loaded. Please note that setting the thermostat higher than the desired temperature will not provide quicker preheat warm-ups.

Warming cabinets are **not** designed to cook food. All foods placed in the warming cabinet should be precooked and at, or above the desired holding temperature. Never place cold or uncooked foods in the cabinet. It is recommended that hot foods be kept above 140°F to retard bacterial growth. Foods that are steaming should always be covered.

Important Note: Although the warming cabinet operating range is 90°F to 180°F, the thermostat control knob can be adjusted up to 200°F. **Never** allow the cabinet temperature to exceed 200°F since serious damage could result to your warming cabinet and the warranty will become null and void.

EVAPORATOR ASSEMBLY

All *value line* and *designer line* refrigerators and freezers have an easily accessible, easily serviceable, performance rated, forced-air evaporator assembly which utilizes a plasticized fin coil for extended life. There are two different types of evaporator assembly systems used throughout the *value line* and *designer line* models as shown in figures 9 and 10:

LOW-PROFILE, CEILING-MOUNT EVAPORATOR ASSEMBLY

The low-profile evaporator system is comprised of a generous sized, evenly matched evaporator and air circulating fans contained within an easily accessible, low silhouette, interior ceiling mounted housing.

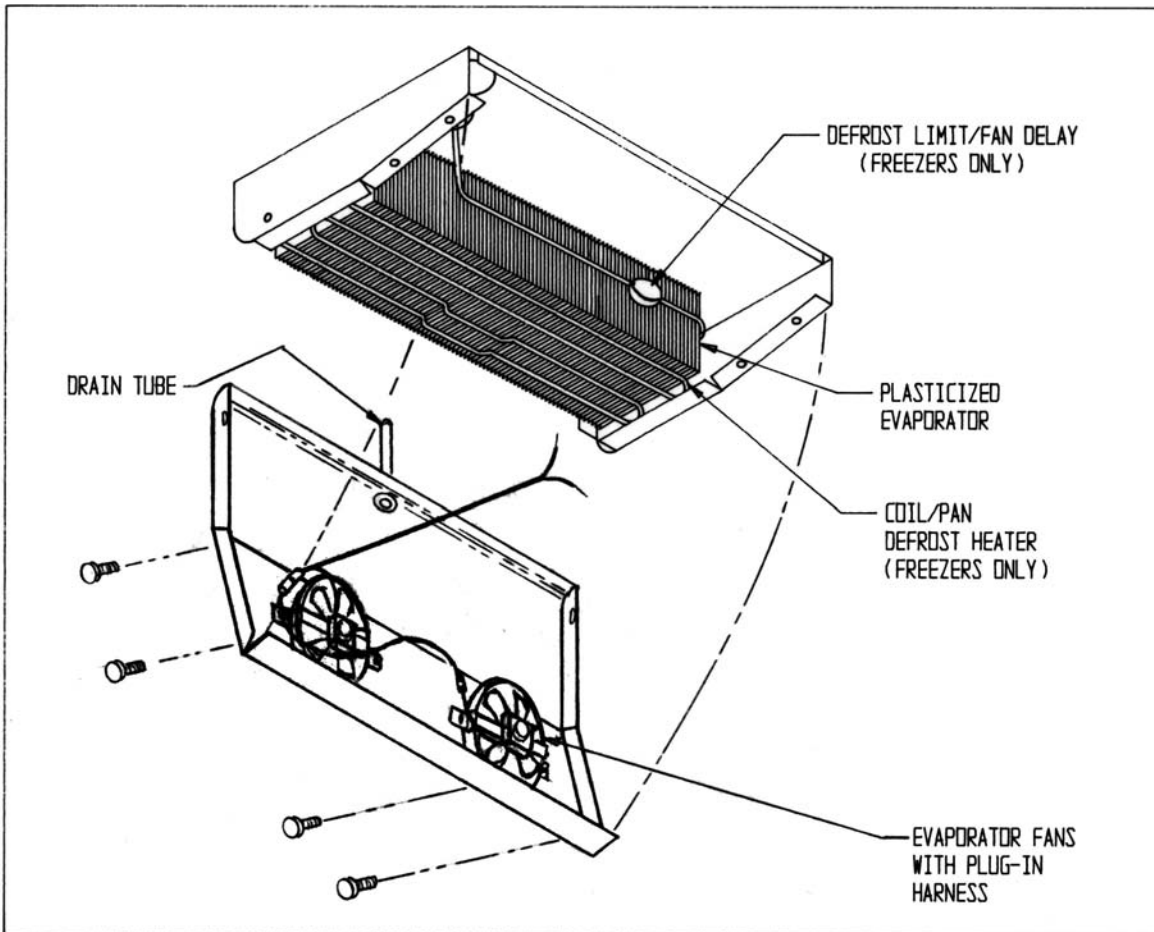

FIGURE 9
LOW-PROFILE, CEILING-MOUNT EVAPORATOR ASSEMBLY

PLUG-TYPE, TOP-MOUNT EVAPORATOR ASSEMBLY

The plug-type evaporator system is a unique system in which the evaporator coil and air circulating fans are contained within a concealed plug-type insulated housing, readily accessible on the top of the cabinet and separate from the food storage zone. The entire plug system is fully charged with refrigerant and mounted on a steel rail type base which can be easily removed from the cabinet if a field conversion (refrigerator to freezer or vice versa) is desired. Before attempting to remove plug assembly, consult factory.

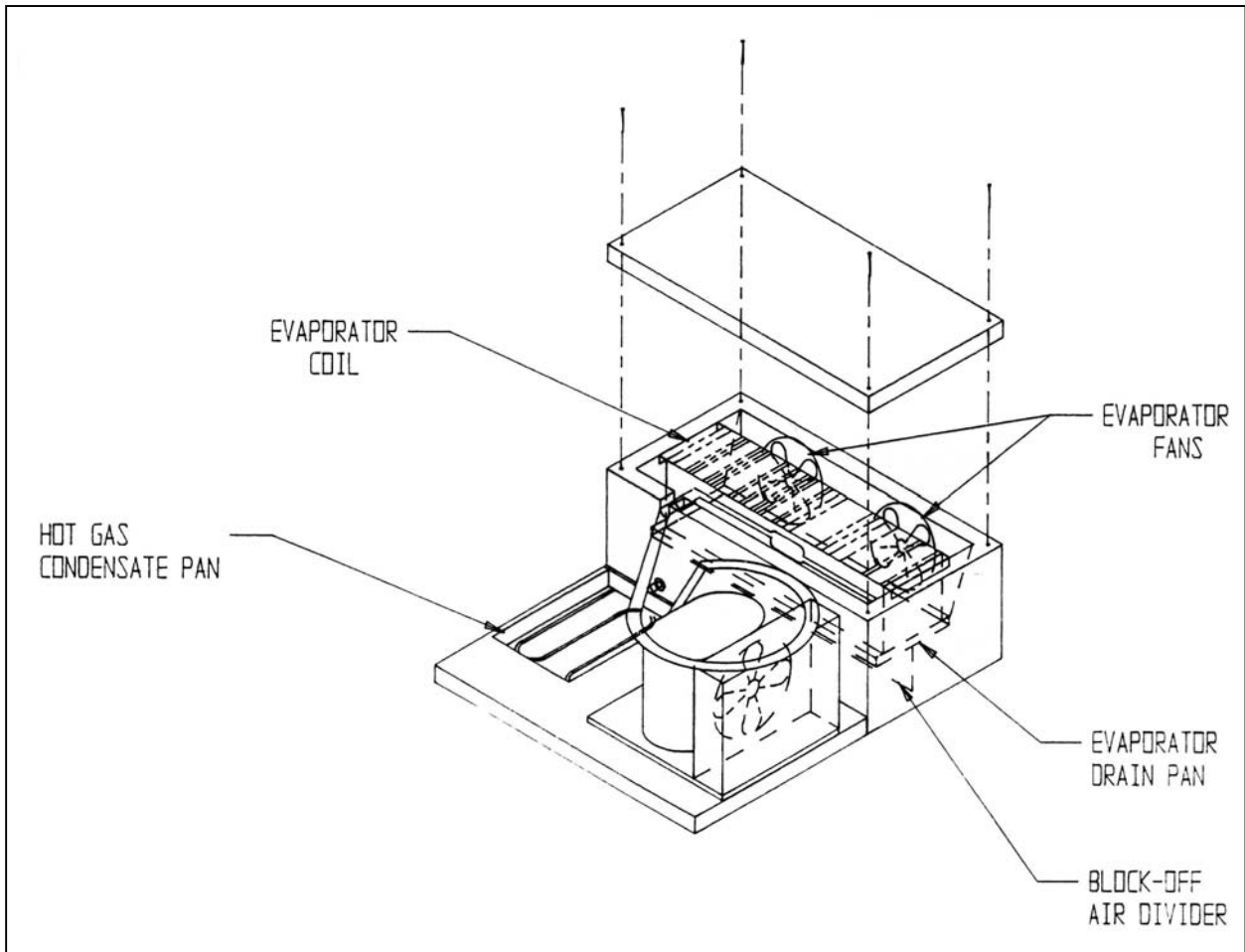

FIGURE 10
PLUG-TYPE, TOP-MOUNT EVAPORATOR ASSEMBLY

INTERIOR REACH-IN ACCESSORIES

The standard interior accessory package that is supplied from the factory with your new *value line* and *designer line* reach-in consists of standard pilaster strips with pilaster clips (four (4) clips per shelf), three (3) epoxy coated shelves per section, and four (4) epoxy coated shelves per section on glass door models only.

SHELVING INSTALLATION

Pilaster strips which support the shelving are secured to the cabinet walls with special pilaster screws which allow the strips to be readily removed for cleaning without the use of tools. Shelf clips are easily installed by inserting them into the pilasters at the desired shelf location and shelf installation is as simple as placing the shelf on the clips as shown in figure 11. The standard pilaster and clip are shown in figure 11a, and the optional heavy-duty pilaster and clip are shown in figure 11b.

Important Note: When loading shelves with food product, allow space between rows of product for proper air circulation, and **do not** load product to block back wall (leave at least 2" of air space between product and back wall).

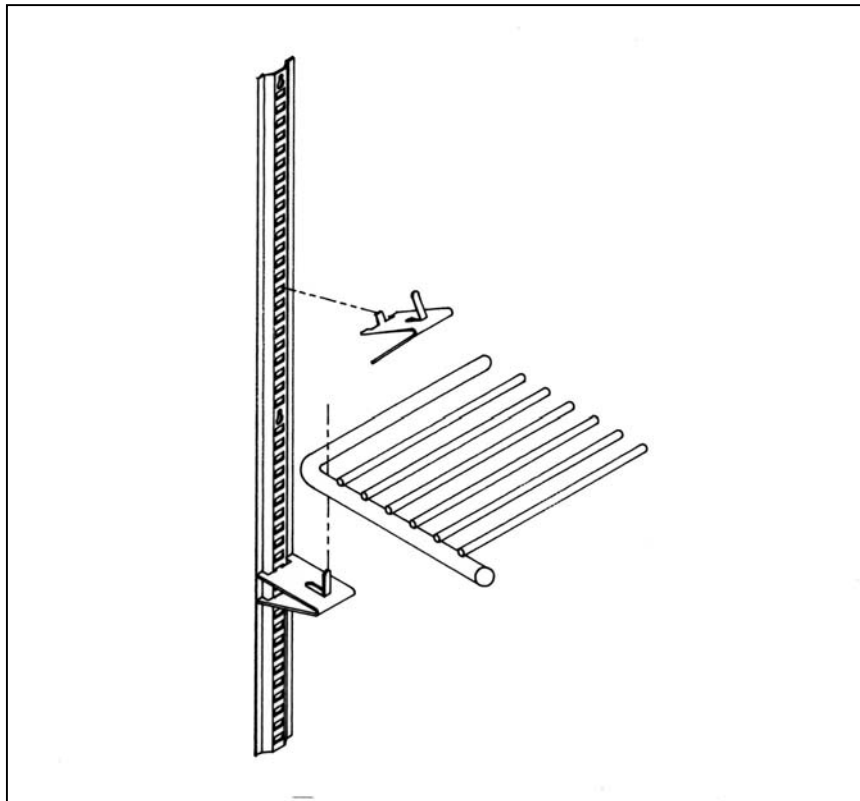

FIGURE 11a
STANDARD PILASTER

OPTIONAL INTERIOR ACCESSORIES

In addition to the optional heavy-duty pilaster and clip as shown in figure 11b, aluminum and stainless steel angle pan slides and universal angle pan slides are available and shown in figure 12. **Please consult the price list for additional interior and exterior options and accessories available from the factory for your model.**

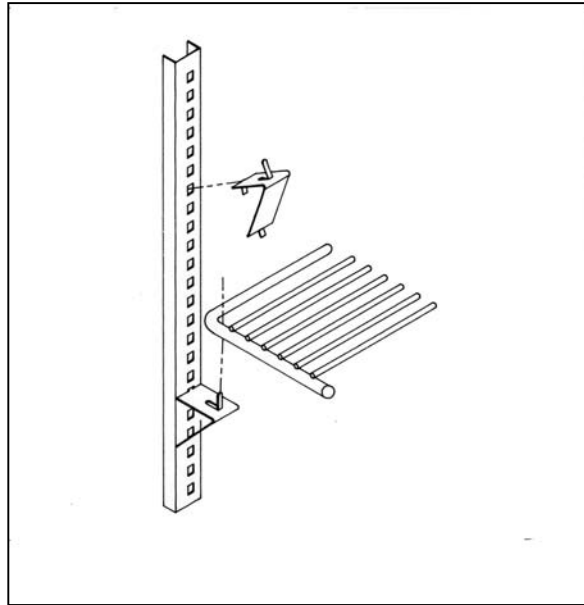

FIGURE 11b
OPTIONAL HEAVY-DUTY PILASTER

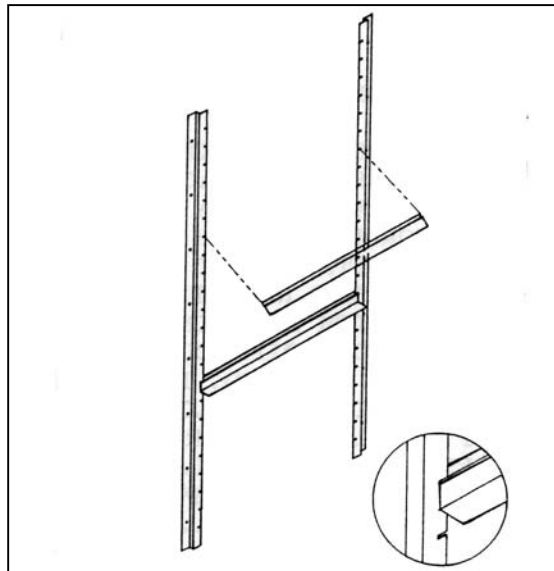

FIGURE 12
OPTIONAL ANGLE PAN SLIDES

SAFETY PRECAUTIONS

The following safety precautions should be followed when operating any appliances:

- ★ Always disconnect the power cord before attempting to work on or clean any equipment.
- ★ Disconnect the power cord when the appliance will be idled for a long period of time.
- ★ **Do not** attempt to service this unit yourself as removing any covers may cause exposure to dangerous voltage.
- ★ Always route the power cord so that it is not likely to be walked on or pinched by other appliances. **Never** use extension cords.
- ★ **Do not** overload outlets with more than one appliance. This can result in fire or electrical shock.
- ★ Your model is equipped with a grounded and polarized plug. Do not defeat the purpose of this plug by removing the ground post or using a non-polarized adapter without properly grounding the outlet.
- ★ Never connect any appliance to a power source while standing in water or with wet hands.
- ★ When a replacement part is required, always insist on factory authorized parts only.

MAINTENANCE

PERIODIC CLEANING PROCEDURE

It is best to clean your refrigerator or freezer when the product load is at its lowest level inside your cabinet. To clean the interior or exterior cabinet surfaces, the following procedure should be followed:

1. Disconnect your model from its power supply and remove all food product from inside.
2. Open all doors and allow the cabinet to reach room temperature. Remove all accessories (shelves, racks, pilasters, clips, etc.) From within the model, wash with a baking soda and warm water solution, and rinse thoroughly with clear water. Dry all of the accessories completely with a soft clean cloth.
3. Once the cabinet has reached room temperature, wash the entire cabinet inside and out with a baking soda and warm water solution. For slightly more difficult cleanups, ammonia or vinegar in warm water can be used. Rinse thoroughly with clear water and dry with a soft clean cloth. Failure to dry all surfaces completely may cause water stains or streaking on the aluminum or stainless steel finish.
4. Return all accessories to their respective positions and return electric supply power to the model.

Precautions

1. Never use harsh detergents, cleaners, scouring powders, or chemicals when cleaning your model.
2. Strong bleaches tend to corrode many materials and should never come in contact with stainless steel.
3. Tincture of iodine, or iron should not come in contact with stainless steel. These solutions, which cause stainless steel to discolor, should be rinsed off immediately if contact occurs.
4. Some foods, such as mustard, mayonnaise, lemon juice, dressings or salts, may attack or corrode stainless steel.
5. Gritty, hard abrasives will mar the finish of stainless steel and aluminum and are not recommended.

SLIDING AND HINGED GLASS

All glass doors whether sliding or hinged are easily removable for cleaning. Removal of a hinged glass door is the same as a solid door (see "removal of doors and door adjustment" in installation and location section). To remove a sliding door, slide it open about half way, grasp the door on both sides and lift up to clear the bottom door track. Tilt the door out at the bottom. Use the top of the door to ease the spring-loaded closing mechanism back to the closed position. Now, bring the door down out of the top track. Caution should be taken so that the closing mechanism is **not** allowed to spring back from the half-open position since the spring will go past the closed position and may pop out of the top track. Should this happen, move the closing mechanism back to the closed position.

To replace the sliding glass door, insert the door in the top track and use it to slide the closing mechanism to the half-open position. Lift the door so it clears the bottom track, push in to align the door with the track, and let the door down into the track.

Important Note: The glass used in sliding or hinged glass doors is of special, sealed pane design and cannot be replaced with ordinary window or plate glass. If it becomes necessary to replace the glass, it can be obtained directly from the factory.

GENERAL PREVENTATIVE MAINTENANCE

Performance of the air cooled condensing unit located on the top of your new model, depends exclusively upon the amount of air passing through the condenser fins. Your refrigerator or freezer will run more efficiently, consume less current, and provide a maximum of trouble-free service throughout its lifetime if the condenser is kept clean and an adequate supply of clean, cool air is provided at all times. Periodically (at least once a month) inspect the condenser coil, which is located directly behind the front top grill, to check for debris or blockage.

TROUBLESHOOTING AND SERVICING GUIDE

PROBLEM	PROBABLE CAUSE	CORRECTION
Condensing unit will not start - no hum.	<ol style="list-style-type: none"> 1.LINE DISCONNECTED, SWITCH OPEN. 2.FUSE REMOVED OR BLOWN. 3.OVERLOAD PROTECTOR BLOWN. 4.CONTROL "OFF" DUE TO COLD LOCATION. 5.CONTROL STUCK IN OPEN POSITION. 6.WIRING IMPROPER OR LOOSE. 	<ol style="list-style-type: none"> 1.CLOSE START OR DISCONNECT SWITCH. 2.REPLACE FUSE. 3.DETERMINE REASON AND CORRECT/REPLACE 4.RELOCATE CONTROL. 5.REPAIR OR REPLACE CONTROL. 6.CHECK WIRING AGAINST DIAGRAM.
Condensing unit will not start - hums but trips on overload protector.	<ol style="list-style-type: none"> 1.IMPROPERLY WIRED. 2.LOW VOLTAGE TO UNIT. 3.STARTING CAPACITOR DEFECTIVE. 4.RELAY FAILING TO CLOSE. 5.COMPRESSOR MOTOR HAS A SHORTED OR OPEN WINDING. 6.INTERNAL MECHANICAL TROUBLE IN COMPRESSOR. 7. INSUFFICIENT AIR SUPPLY 	<ol style="list-style-type: none"> 1.CHECK WIRING AGAINST DIAGRAM. 2.DETERMINE REASON AND CORRECT. 3.DETERMINE REASON AND REPLACE. 4.DETERMINE REASON AND REPLACE. 5.REPLACE COMPRESSOR. 6.REPLACE COMPRESSOR. 7. CLEAR CONDENSER & ALLOW COMPRESSOR TO COOL DOWN
Condensing unit starts and runs, but short cycles on over-load protector.	<ol style="list-style-type: none"> 1.ADDITIONAL CURRENT PASSING THROUGH OVERLOAD PROTECTOR. 2.LOW VOLTAGE TO UNIT. 3.OVERLOAD PROTECTOR DEFECTIVE. 4.RUN CAPACITOR DEFECTIVE. 5.EXCESSIVE DISCHARGE PRESSURE. 6.EXCESSIVE SUCTION PRESSURE. 7.INSUFFICIENT AIR SUPPLY 	<ol style="list-style-type: none"> 1.CHECK WIRE DIAGRAM.CHECK FOR ADDED COMPONENTS CONNECTED TO WRONG SIDE OF OVERLOAD PROTECTOR. 2.DETERMINE REASON AND CORRECT. 3.CHECK CURRENT,REPLACE PROTECTOR. 4.DETERMINE REASON AND REPLACE. 5.CHECK VENTILATION,RESTRICTIONS IN COOLING MEDIUM OR REFRIG. SYSTEM. 6.CHECK FOR MISAPPLICATION. 7.CLEAR CONDENSER & ALLOW COMPRESSOR TO COOL DOWN
Condensing unit starts, but fails to switch off of "start" winding.	<ol style="list-style-type: none"> 1.IMPROPERLY WIRED. 2.LOW VOLTAGE TO UNIT. 3.RELAY FAILING TO OPEN. 4.RUN CAPACITOR DEFECTIVE. 5.EXCESSIVELY HIGH DISCHARGE PRESSURE. 6.COMPRESSOR MOTOR HAS A SHORTED OR OPEN WINDING. 7.INTERNAL MECHANICAL TROUBLE IN COMPRESSOR. 	<ol style="list-style-type: none"> 1.CHECK WIRING AGAINST DIAGRAM. 2.DETERMINE REASON AND CORRECT. 3.DETERMINE REASON AND REPLACE. 4.DETERMINE REASON AND REPLACE. 5.CHECK DISCHARGE SHUT-OFF VALVE, POSSIBLE OVERCHARGE. 6.REPLACE COMPRESSOR. 7.REPLACE COMPRESSOR.

PROBLEM	PROBABLE CAUSE	CORRECTION
Condensing unit runs, but short cycles on:	1.OVERLOAD PROTECTOR. 2.THERMOSTAT. 3.HIGH PRESSURE CUT-OUT DUE TO: (a) INSUFFICIENT AIR SUPPLY. (b) OVERCHARGE. (c) AIR IN SYSTEM. 4.LOW PRESSURE CUT-OUT DUE TO: (a) VALVE LEAK. (b) UNDERCHARGE. (c) RESTRICTION IN EXPANSION DEVICE.	1.SEE PROBLEM # 3. 2.DIFFERENTIAL MUST BE WIDENED. 3. (a) CHECK AIR SUPPLY TO CONDENSER. (b) EVACUATE AND RE-CHARGE. (c) EVACUATE AND RE-CHARGE. 4. (a) REPLACE, EVACUATE AND RE-CHARGE. (b) EVACUATE AND RE-CHARGE. (c) REPLACE EXPANSION DEVICE.
Condensing unit runs, but for prolonged periods or continuous.	1.SHORTAGE OF REFRIGERANT. 2.CONTROL CONTACTS STUCK CLOSED. 3.EXCESSIVE HEAT LOAD PLACED INTO CABINET. 4.PROLONGED OR TOO FREQUENT DOOR OPENINGS. 5.EVAPORATOR COIL ICED. 6.RESTRICTION IN REFRIGERATION SYSTEM. 7.DIRTY CONDENSER. 8.FILTER DRIER CLOGGED.	1.FIX LEAK,EVACUATE AND RE-CHARGE. 2.CLEAN CONTACTS OR REPLACE CONTROL. 3.ALLOW UNIT SUFFICIENT TIME FOR REMOVAL OF LATENT HEAT. 4.PLAN OR ORGANIZE SCHEDULE TO CORRECT CONDITION. 5.DEFROST EVAPORATOR COIL. 6.DETERMINE LOCATION AND REMOVE. 7.CLEAN CONDENSER COIL. 8.REPLACE,EVACUATE AND RE-CHARGE.
Start capacitor open, shorted or blown.	1.RELAY CONTACT NOT OPENING PROPERLY. 2.PROLONGED OPERATION ON START CYCLE: (a) LOW VOLTAGE TO UNIT. (b) IMPROPER RELAY. (c) STARTING LOAD TOO HIGH. 3.EXCESSIVE SHORT CYCLING. 4.IMPROPER CAPACITOR.	1.CLEAN CONTACTS OR REPLACE RELAY. 2. (a) DETERMINE REASON AND CORRECT. (b) REPLACE WITH CORRECT RELAY. (c) CORRECT BY USING PUMP DOWN. 3.DETERMINE REASON FOR SHORT CYCLE, (SEE PROBLEM #5) AND CORRECT. 4.DETERMINE CORRECT SIZE AND REPLACE.
Run capacitor open, shorted or blown.	1.IMPROPER CAPACITOR. 2.EXCESSIVELY HIGH LINE VOLTAGE, OVER 110% OF RATED MAXIMUM.	1.CHECK SIZE AND REPLACE. 2.DETERMINE REASON AND CORRECT.
Relay defective or blown out.	1.INCORRECT RELAY. 2.INCORRECT MOUNTING ANGLE. 3.VOLTAGE TOO LOW OR TOO HIGH. 4.EXCESSIVE SHORT CYCLING. 5.LOOSE OR VIBRATING MOUNTING POSITION 6.INCORRECT RUN CAPACITOR. 7.LOOSE WIRING ON RELAY OR OVERLOAD.	1.CHECK RELAY AND REPLACE. 2.REMOUNT RELAY IN CORRECT POSITION. 3.DETERMINE REASON AND CORRECT. 4.DETERMINE REASON AND CORRECT (SEE PROBLEM # 5). 5.REMOUNT RIGIDLY. 6.REPLACE WITH PROPER CAPACITOR. 7.TIGHTEN ALL WIRING SCREWS.

PROBLEM	PROBABLE CAUSE	CORRECTION
Product zone temperature too high.	1.CONTROL SETTING TOO HIGH. 2.INADEQUATE AIR CIRCULATION. 3.DIRTY CONDENSER	1.ADJUST T-STAT 2.REARRANGE PRODUCT LOAD TO IMPROVE AIR CIRCULATION. 3.CLEAN CONDENSER COIL
Suction line frosted or sweating.	1.OVERCHARGE OF REFRIGERANT. 2.EVAPORATOR FAN NOT RUNNING. 3.EXPANSION VALVE STUCK OPEN. 4.EXPANSION VALVE SUPERHEAT TOO LOW.	1.EVACUATE AND RE-CHARGE. 2.DETERMINE REASON AND CORRECT. 3.CLEAN VALVE,EVACUATE AND RE-CHARGE. 4.ADJUST SUPERHEAT TO REQUIRED SETTING
Liquid line frosted, cold, or sweating.	1.RESTRICTION IN DRIER STRAINER. 2.LIQUID LINE SERVICE VALVE PARTIALLY CLOSED.	1.REPLACE DRIER,EVACUATE AND RE-CHARGE 2.OPEN VALVE FULLY OR REPLACE IF NECESSARY.
Noisy condensing unit.	1.LOOSE PARTS OR MOUNTINGS. 2.TUBING RATTLE OR VIBRATION. 3.BENT FAN BLADE CAUSING EXCESSIVE VIBRATION. 4.FAN MOTOR BEARINGS WORN.	1.TIGHTEN ALL MOUNTING PARTS AND SHROUD COVER. 2.REFORM TUBING TO BE FREE OF CONTACT. 3.REPLACE FAN BLADE. 4.REPLACE FAN MOTOR.
THERMOMETER READS DIFFERENT THAN ACTUAL TEMPERATURE	1.CALIBRATION 2.DEFECTIVE	1.CONSULT OPERATIONS MANUAL AND CALIBRATE 2.REPLACE
WATER LEAK INSIDE UNIT	1.CONDENSATE DRAIN PAN NOT INSTALLED PROPERLY 2.UNIT NOT LEVEL 3.DRAIN PAN MISALIGNED 4.DEFECTIVE DRAIN PAN	1.CONSULT OPERATION MANUAL FOR INSTALL INSTRUCTION 2.MAKE SURE UNIT IS LEVEL OR PITCHED BACK SLIGHTLY 3.MAKE SURE DRAIN PAN IS ALIGNED PROPERLY 4.REPLACE
DOORS MISALIGNED	1.SHIFTED DURING SHIPPING	1.REFER TO OPERATION MANUAL FOR HINGE ADJUSTMENT

WIRING DIAGRAMS

SELF-CONTAINED REFRIGERATOR 115/60/1

WD-R1

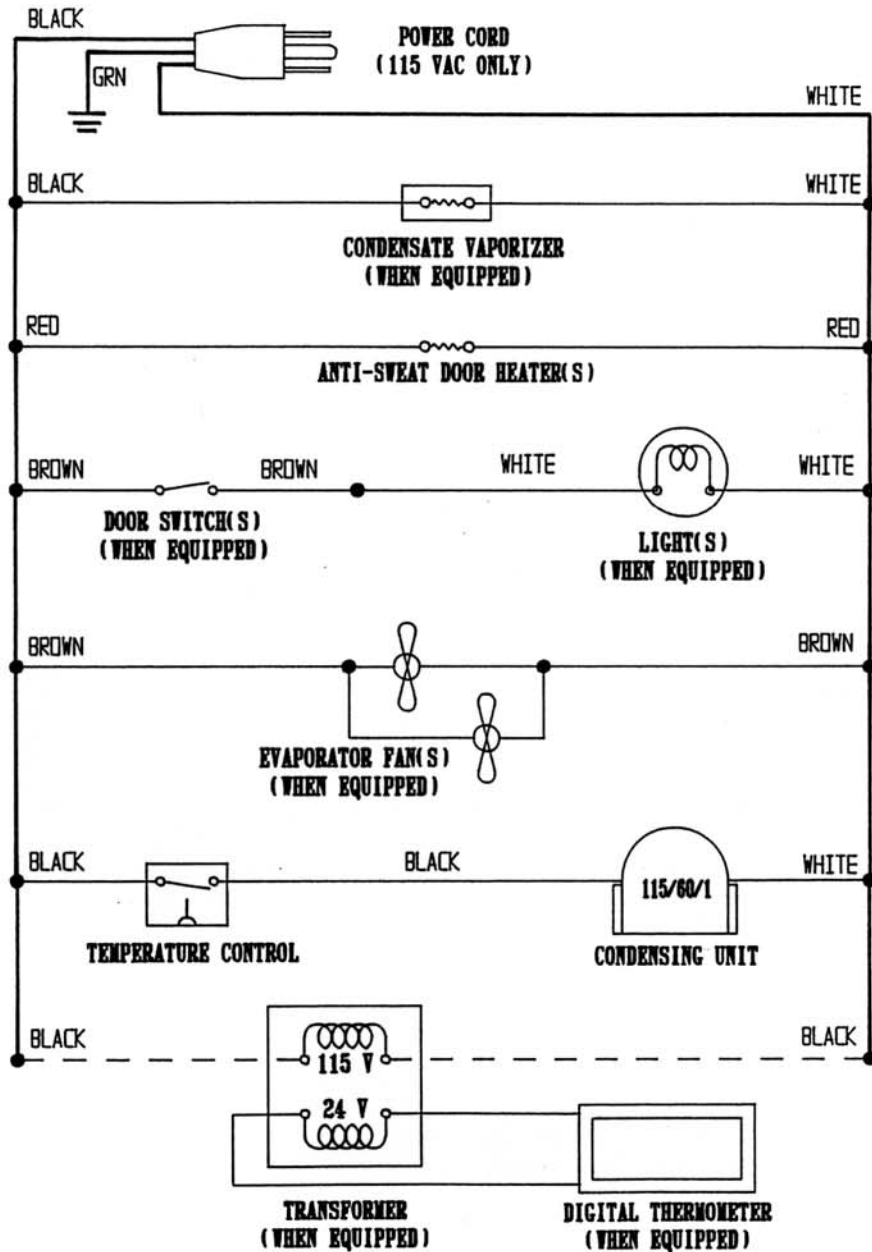

Continental REFRIGERATOR
 A Division of National Refrigeration & A/C Products, Inc.

SELF-CONTAINED REFRIGERATOR

WD-R2

115/208-230/60/1

(115 VOLT CABINET, 208-230 VOLT CONDENSING UNIT)

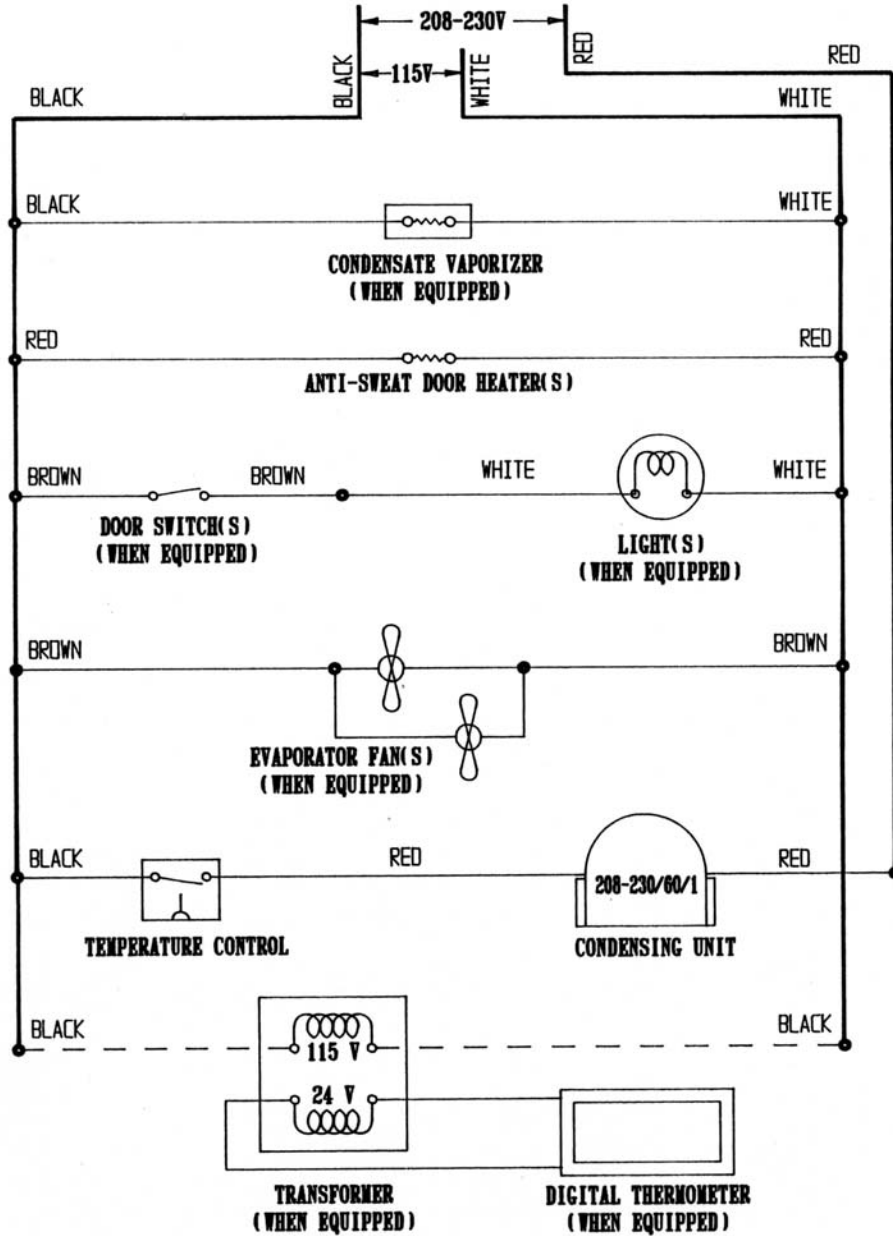

Continental REFRIGERATOR
 A Division of National Refrigeration & A/C Products, Inc.

SELF-CONTAINED GLASS DOOR REFRIGERATOR WD-R3 115/60/1

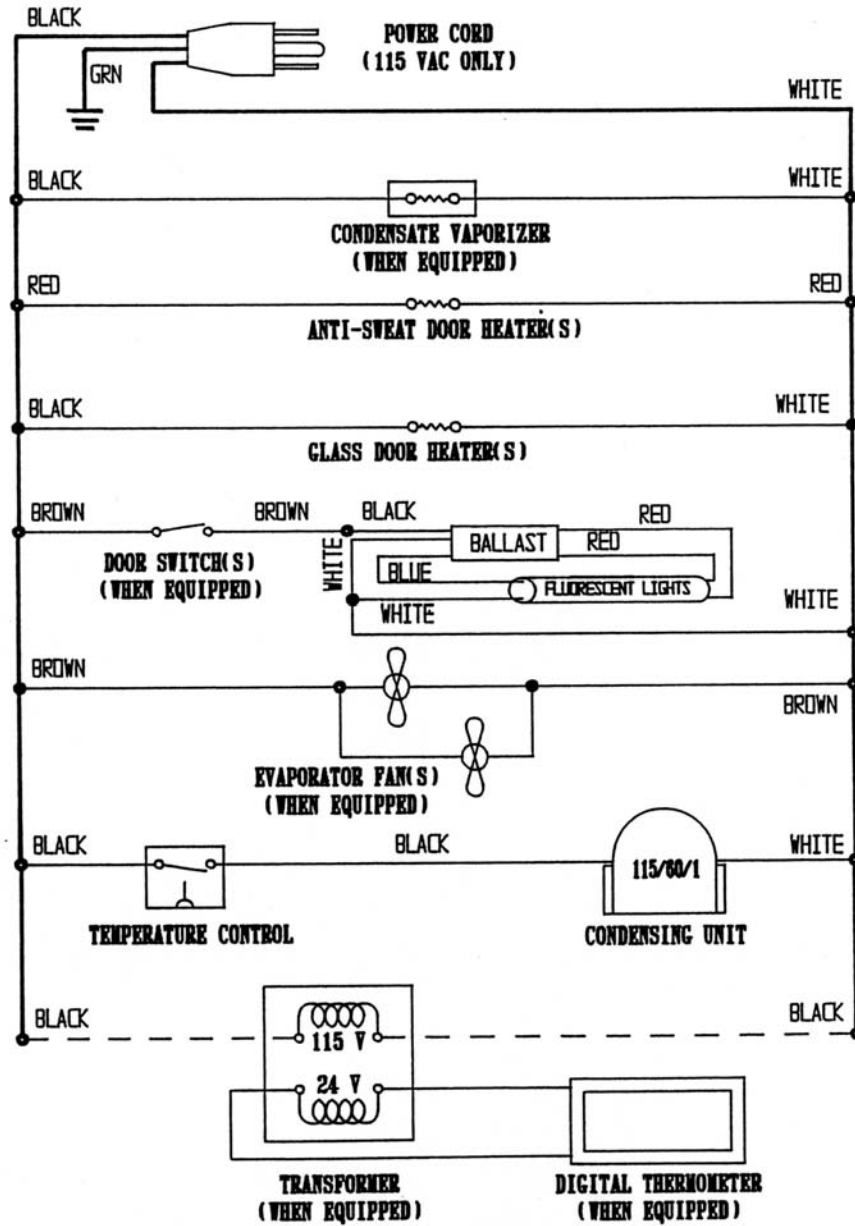

Continental REFRIGERATOR
A Division of National Refrigeration & A/C Products, Inc.

SELF-CONTAINED GLASS DOOR REFRIGERATOR WD-R4
115/208-230/60/1
(115 VOLT CABINET, 208-230 VOLT CONDENSING UNIT)

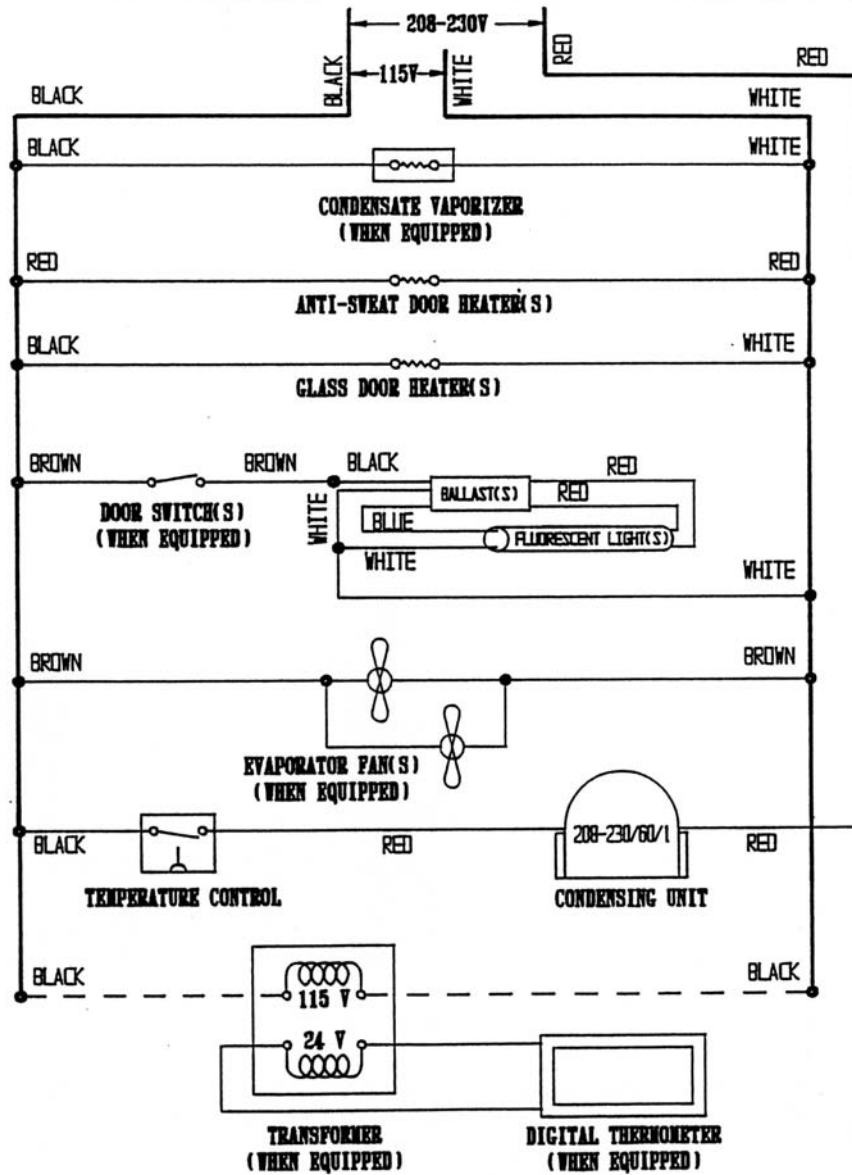

Continental REFRIGERATOR
 A Division of National Refrigeration & A/C Products, Inc.

SELF-CONTAINED FREEZER 115/60/1

WD-F1

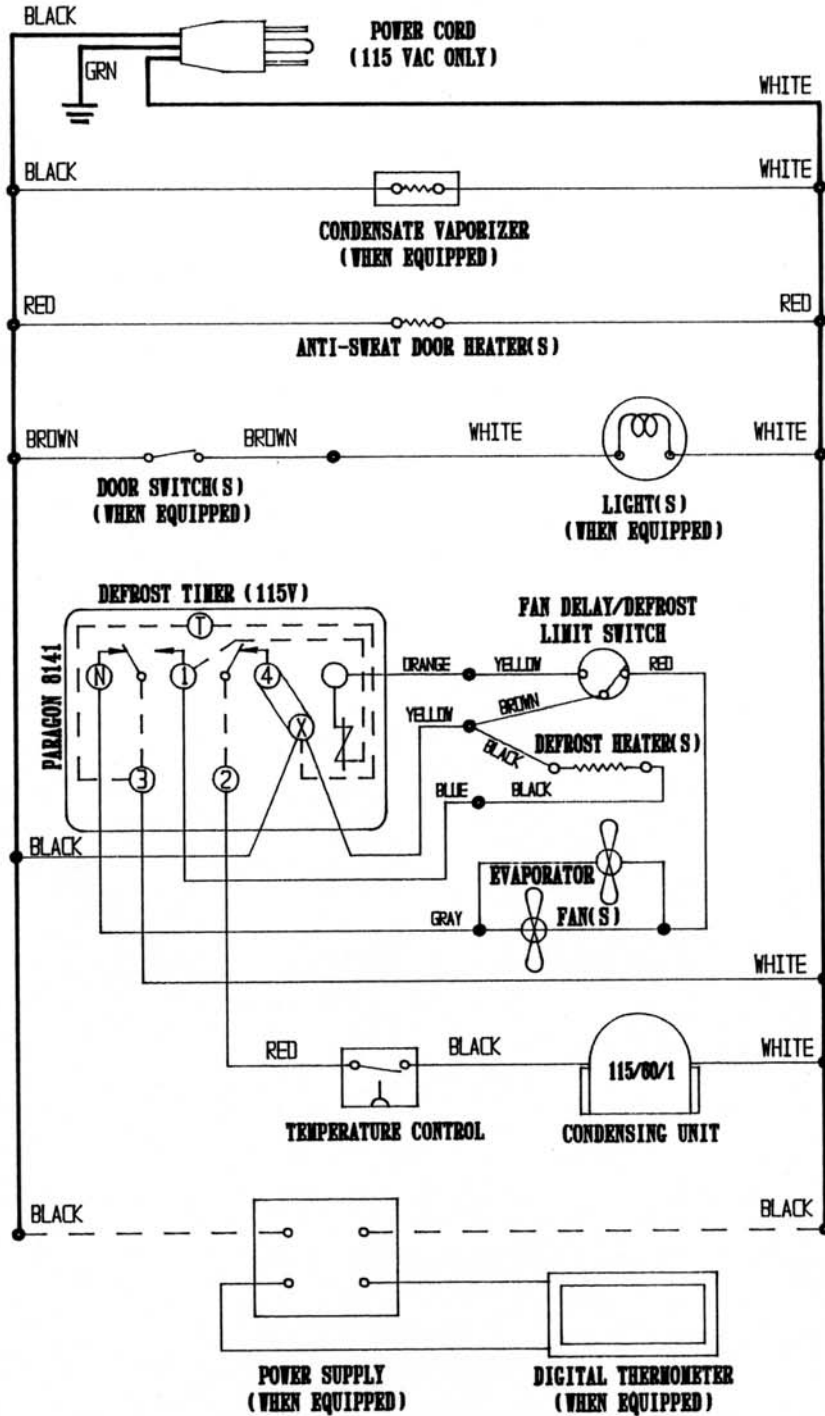

Continental REFRIGERATOR
A Division of National Refrigeration & A/C Products, Inc.

SELF-CONTAINED FREEZER

WD-F2

115/208-230/60/1

(115 VOLT CABINET, 208-230 VOLT CONDENSING UNIT)

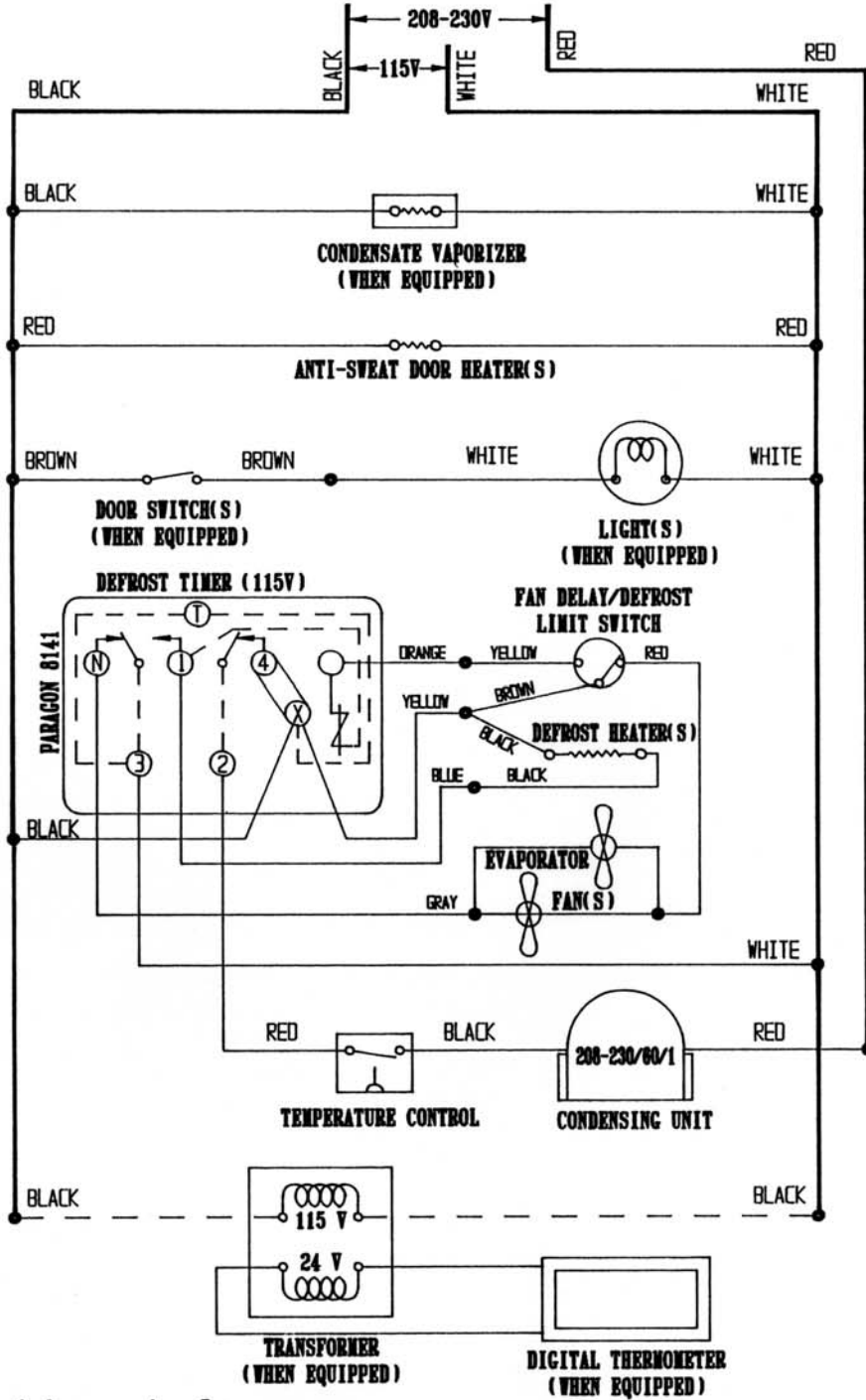

Continental REFRIGERATOR
 A Division of National Refrigeration & A/C Products, Inc.

SELF-CONTAINED GLASS DOOR FREEZER 115/60/1

WD-F3

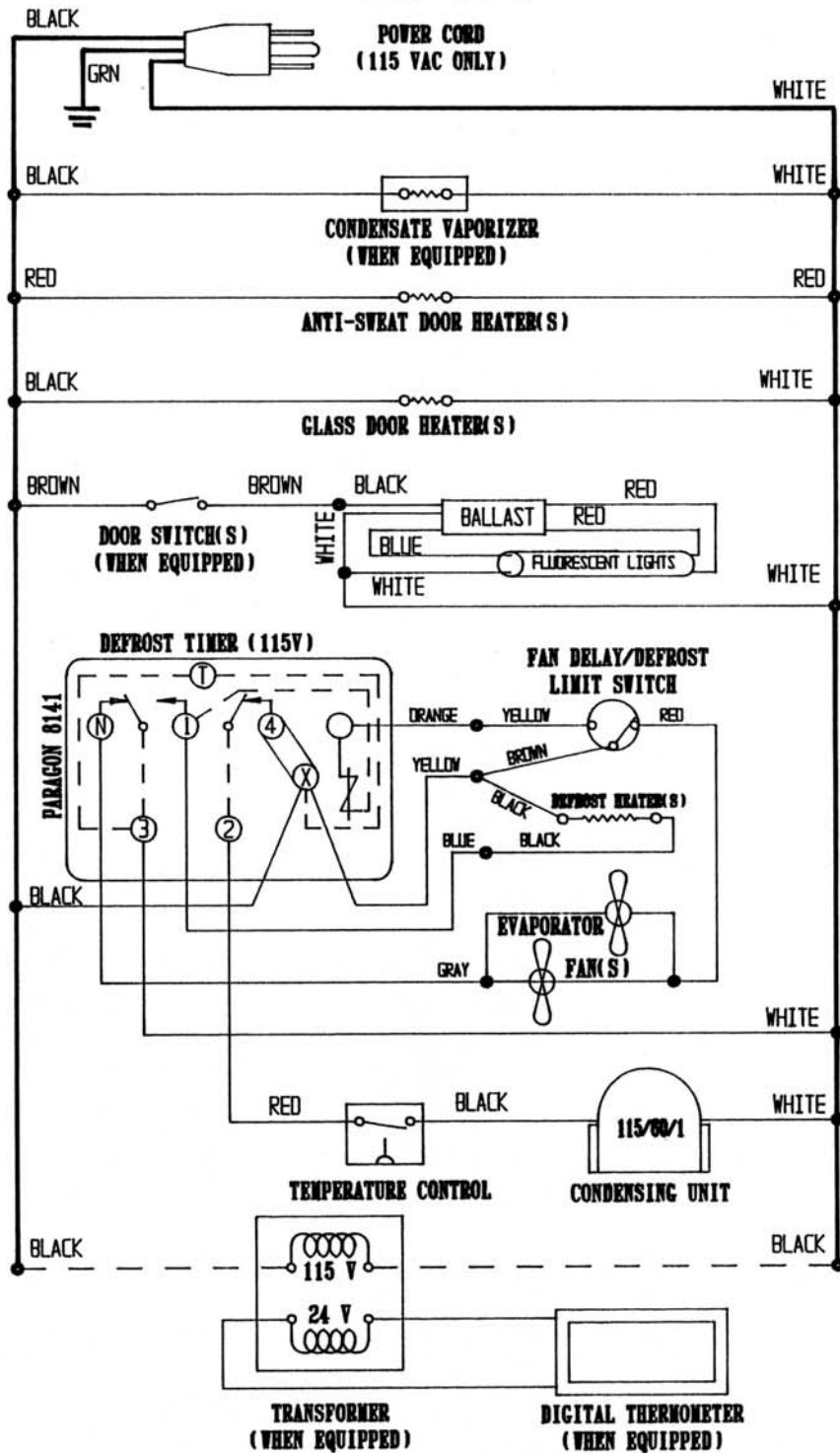

Continental REFRIGERATOR
A Division of National Refrigeration & A/C Products, Inc.

SELF-CONTAINED GLASS DOOR FREEZER WD-F4
115/208-230/60/1
(115 VOLT CABINET, 208-230 VOLT CONDENSING UNIT)

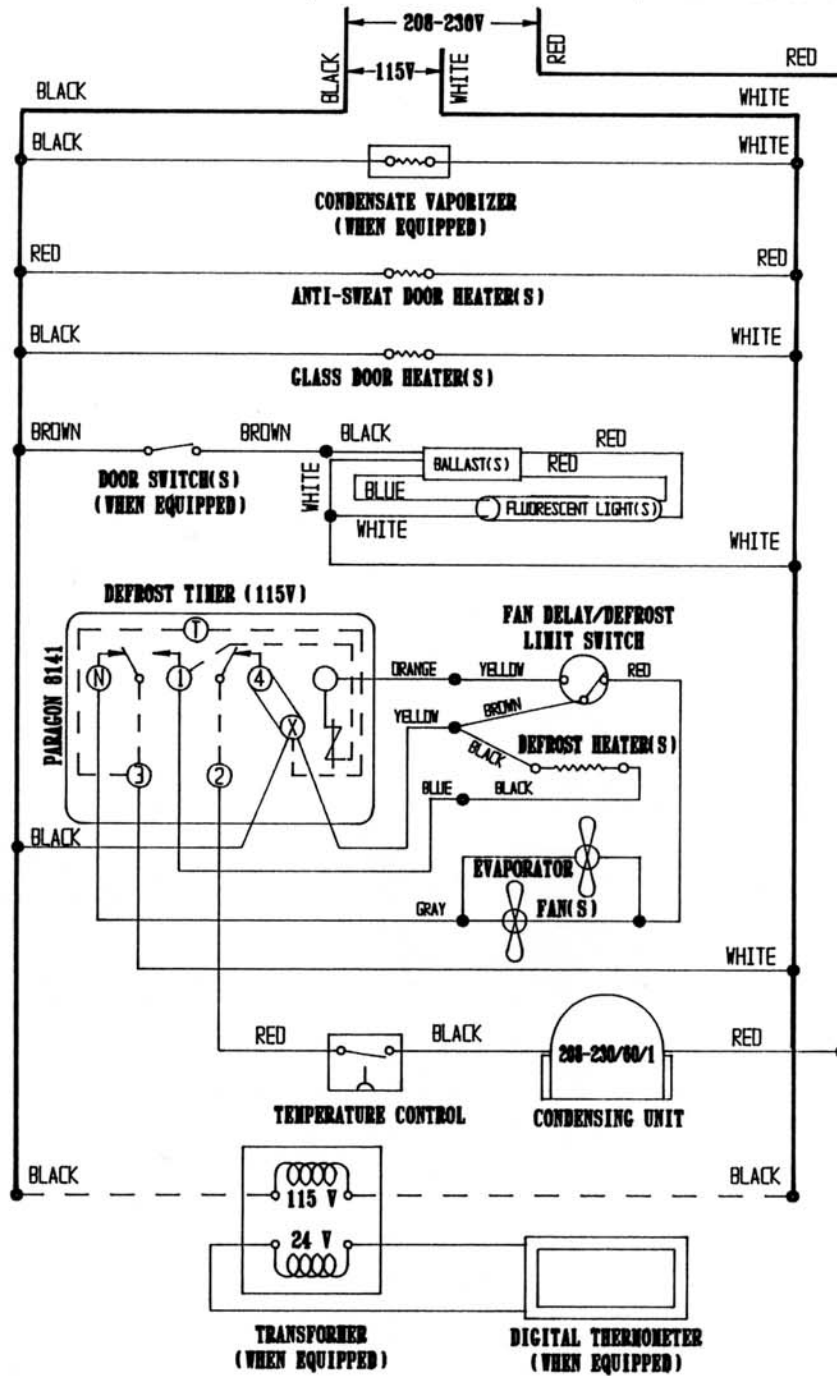

Continental REFRIGERATOR
 A Division of National Refrigeration & A/C Products, Inc.

